

mee-go®

pure



Dear Customer,

Thank you for purchasing the Pure lightweight travel system.

For the safety of you child, you must read and follow these instructions carefully.

This product has been manufactured under quality surveillance and been tested to EN1888-2:2018 and BS EN1466:2014.

**IMPORTANT- READ CAREFULLY AND KEEP FOR FUTURE REFERENCE**

## **WARNING:**

- Never leave your child unattended.
- Ensure that all the locking devices are engaged before use.
- To avoid injury ensure that your child is kept away when unfolding and folding this product.
- Do not let your child play with this product.
- Always use the restraint system.
- Check that the pram body or seat unit attachment devices are correctly engaged before use.
- This product is not suitable for running or skating.
- Lock the brake when you place your child into the travel system and lock again when you remove your child.
- Regularly check if there's any visible damage to the handle and base unit.
- The carrycot is suitable for a baby from 0 to 6 months up to a maximum weight of 9kg.
- The maximum loading for the storage basket is 5kg.
- This travel system is designed and tested to be used with the carrycot or the seat unit.
- Do not use more than 1 mattress in the carrycot. Do not use a mattress thicker than 20mm.
- Any additional load attached to the handle and/or on the back of the backrest and/or on the sides of the travel system will affect its stability.
- Do not carry more than one child in this travel system.
- Do not use extra accessories not intended for the travel system and only use replacement parts supplied & approved by the manufacturer.
- The carrycot is only suitable for a child who cannot sit up unaided, cannot roll over and cannot push itself up to its hands and knees.
- Maximum weight of the child using this carrycot is 9kg.
- This travel system does not replace a cot or a bed.
- Never use this travel system on a stand or platform.
- Use only on firm, horizontal, level and dry surfaces.
- Do not let other children play unattended near the travel system.
- Do not use, if any part of the travel system is broken, torn or missing.
- Do not place the travel system near an open fire or other source of strong heat.
- In stroller mode the seat unit is suitable up to a maximum child's weight of 22 kg or 4 years old, whichever comes first.

# Parts

Canopy

Handle bar

Chest pads

Safety harness

Button to remove bumper bar

Button to adjust angle of the footrest

Front wheels

Rear wheels

Lever for seat unit adjustment

Button to adjust handle bar

Bumper bar

Basket

Brake bar

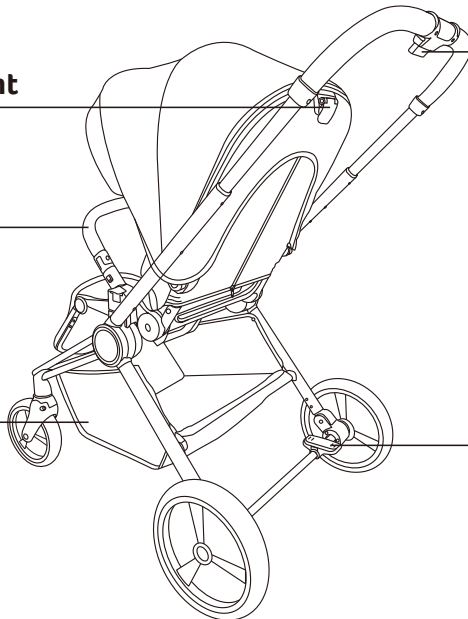
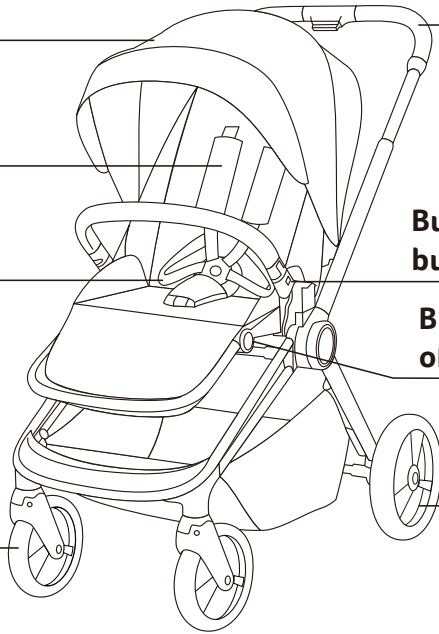

## Assembling the travel system

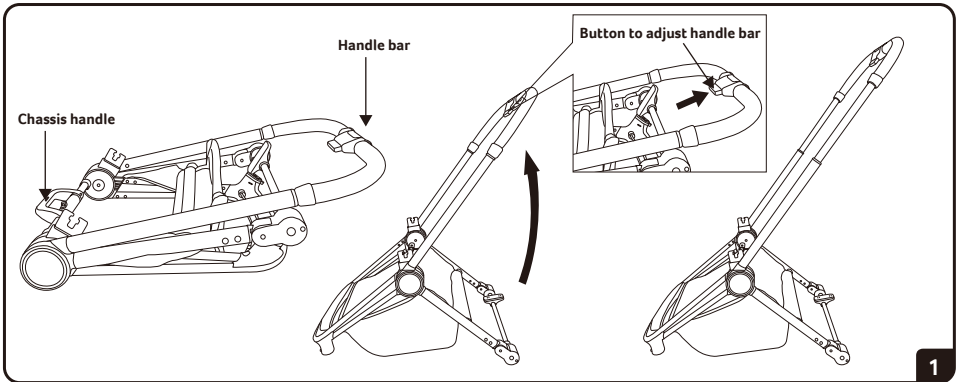

1. To unfold the chassis, lift up the chassis holding the chassis handle with one hand and then pull the handle bar upwards with your second hand. You will hear a “click” to indicate the chassis is locked open. To adjust the height of the handle bar, press the handle bar adjustment button and pull the handle bar upwards, it will “click” into each height position.

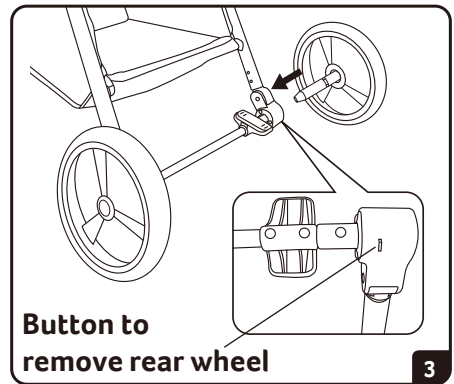
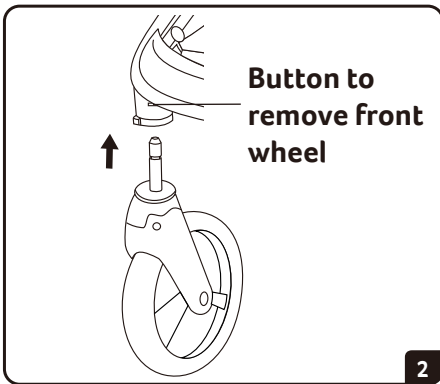

2. To install the front wheels, push each front wheel into the front wheel bracket until you hear a “click”. To remove the front wheels, press the button on the front wheel bracket whilst pulling the wheel downwards. To install the back wheels, push each back wheel into the back wheel axle until you hear a “click”. To remove the back wheels, press the button on the back wheel axle whilst pulling the wheel outwards.

## Assembling the travel system

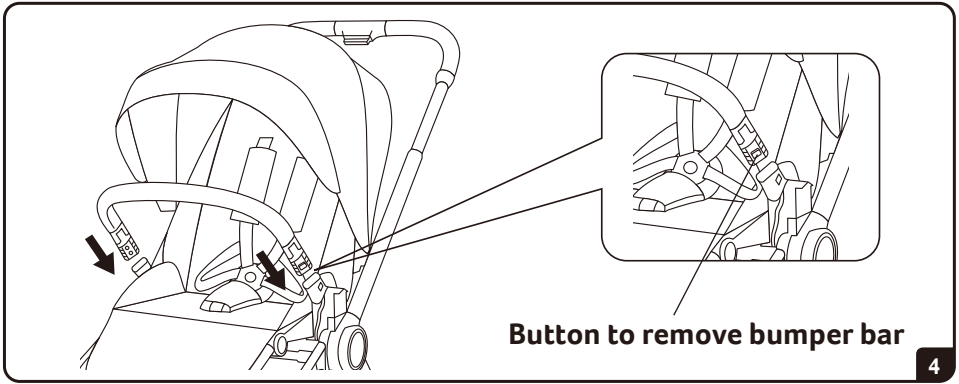

- 4. To install the bumper bar, insert each end of the bar into the connectors situated on the side of the seat unit. You will hear a “click” to indicate the bar is locked in position.**  
**To remove the bumper bar, press both buttons on the outer sides of the connectors and pull the bumper bar upwards.**

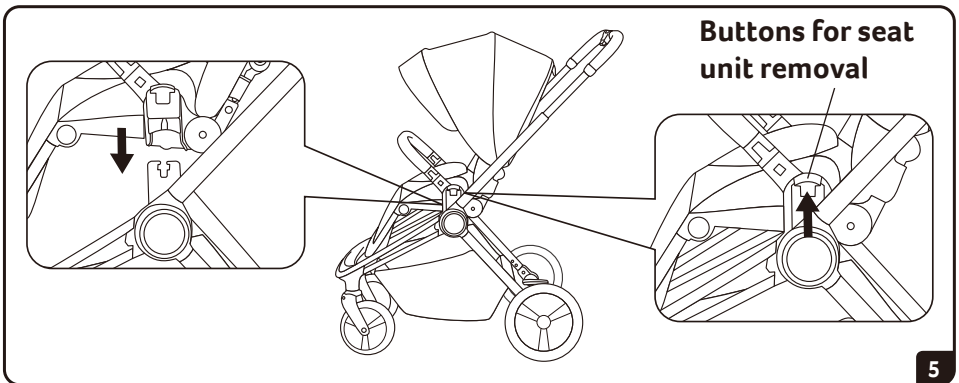

- 5. The seat unit can be installed either forward facing or parent facing.**  
**To install the seat unit, insert the frame supports on the seat unit into the connectors situated on the side of the chassis, ensuring the seat is parallel to the chassis before pushing downwards. You will hear a “click” to indicate the seat unit is locked in position.**

**To remove the seat unit, press the buttons on each side then lift it upwards by holding the bumper bar.**

- 6. To assemble the carrycot, first unzip the liner to access the carrycot structure. Push the support bars outwards until they lock into the location points. Zip the liner back into the carrycot and insert the mattress.**

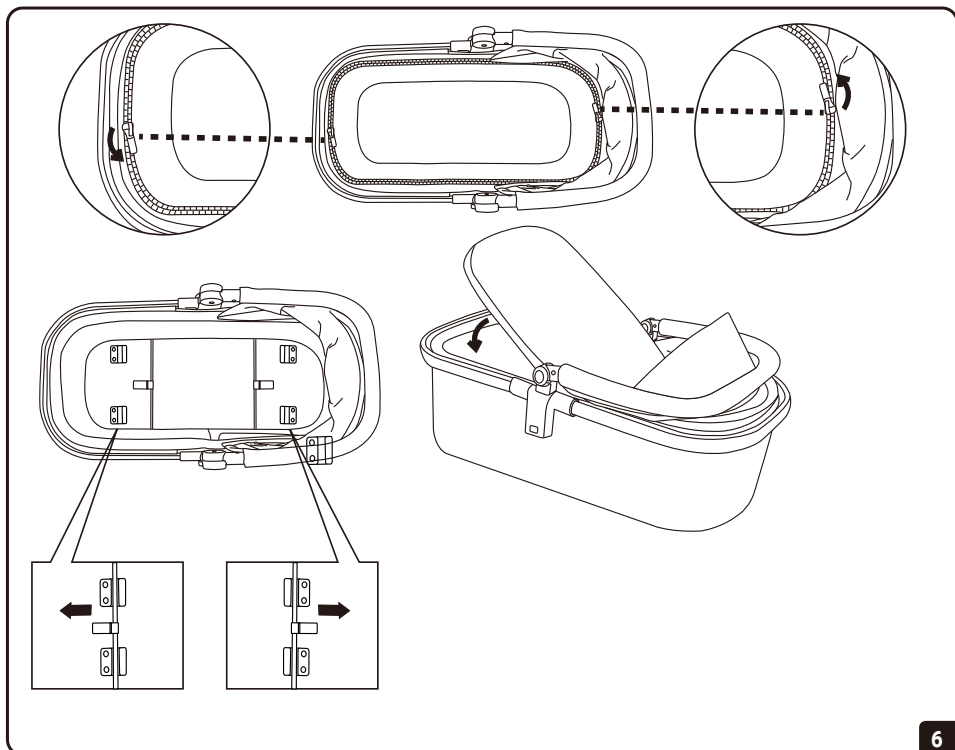

6

### **Attention:**

- 1. The carrycot is only suitable for children who are not yet able to sit up or stand on their own.**
- 2. Use only on firm, horizontal, level and dry surfaces.**
- 3. When using the carrycot, the child's head should always be higher than his body.**
- 4. Ensure the handle is locked in position before carrying or lifting.**
- 5. The carrycot must be used in conjunction with the adapters supplied.**

7. Attach the carrycot adapters onto the connectors, situated on each side of the chassis. Then insert the frame supports on the carrycot unit into the adapters, ensuring the carrycot is parallel to the chassis before pushing downwards. You will hear a “click” to indicate the carrycot is locked in position.

To remove the carrycot, press the buttons on each side then lift upwards. To remove the adapters, press the adapter button then pull.

To adjust the hood, press the button on each side, then rotate the hood open or closed.

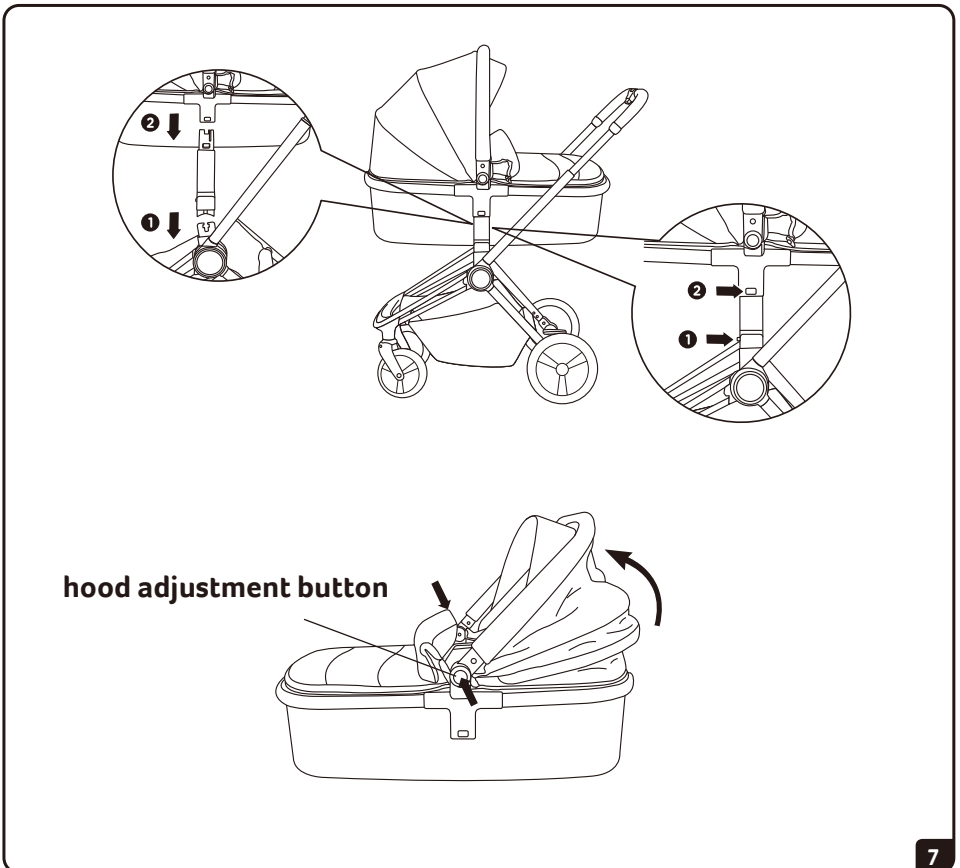

## Instructions for use

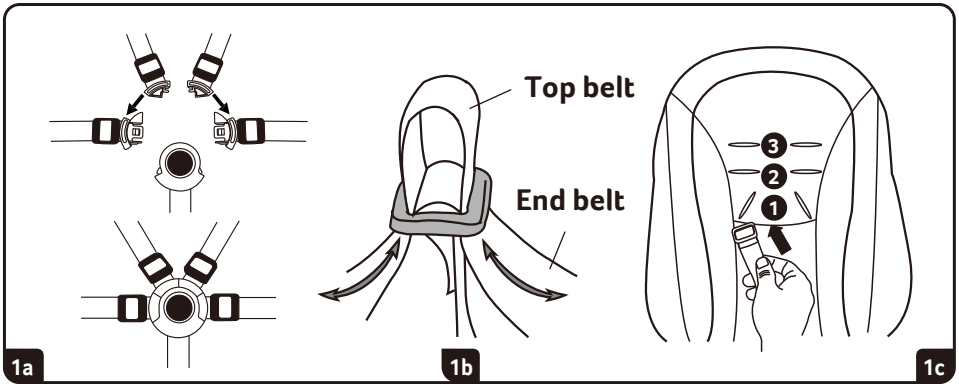

- 1a.** To use the safety belt, insert each buckle into the buckle socket, a “click” sound will indicate they have locked into position. To open press the central button and the separate buckles will open apart.
- 1b.** Use the plastic adjuster on the webbing straps to lengthen or shorten the belts as required.
- 1c.** To attach the safety belts to the seat unit, pass the belt end tabs through the opening in the seat cover until the tabs pass through the back plate of the seat unit. Ensure the belt end tabs are flat against the backing board.

## Instructions for use

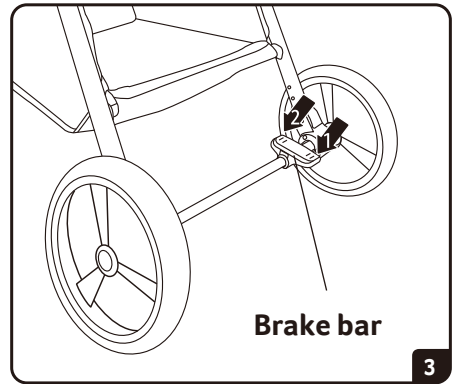
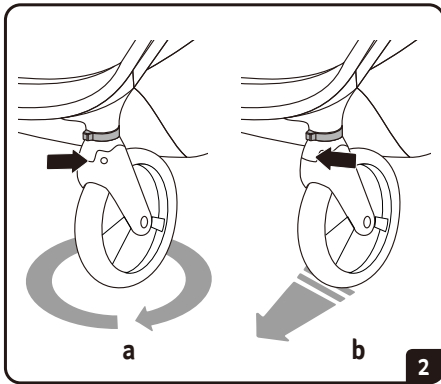

**2. The front wheels can be fixed or rotate freely.**

To allow the front wheels to rotate, pull the button outwards, to fix the wheels push the button inwards.

**3. To apply the rear wheel brake, step down on the brake bar in position "1". To release the brake step on the brake bar in position "2".**

**Attention: when the stroller is stationary, always apply the brake.**

## Instructions for use

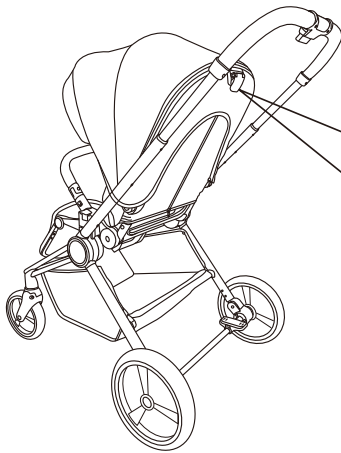

**Lever for seat unit adjustment**

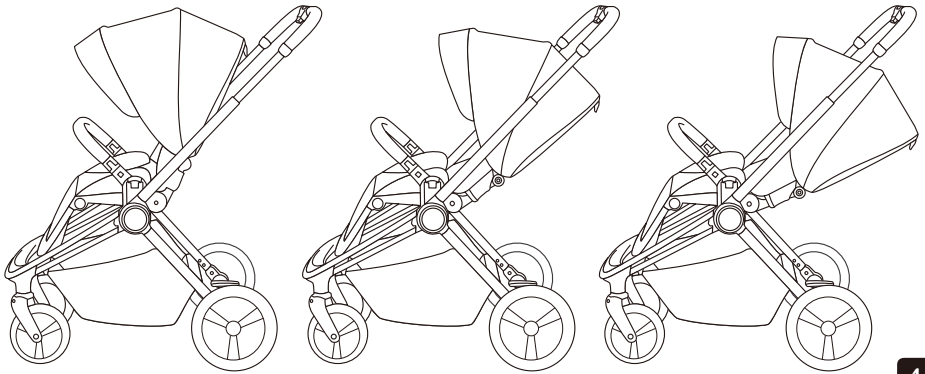

4

- 4. To adjust the angle of the backrest, pull the seat adjustment lever and move the seat back up or down. Three different angles can be achieved**

## Instructions for use

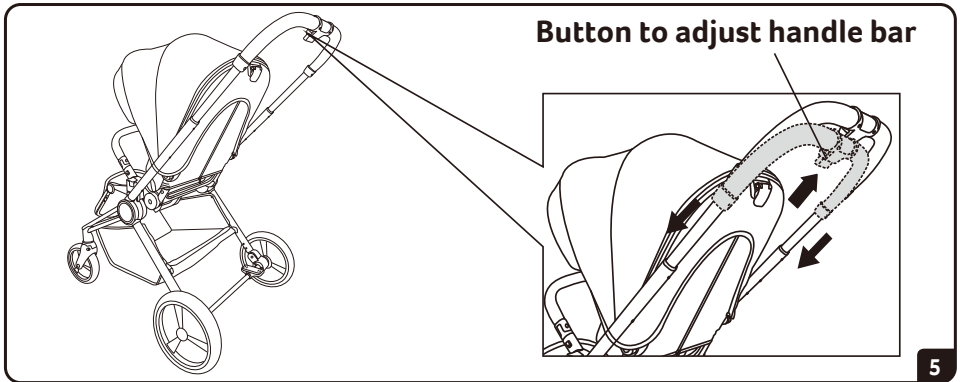

5. To adjust the height of the handle bar, press the button and pull / push the handle bar up or down to desired height.

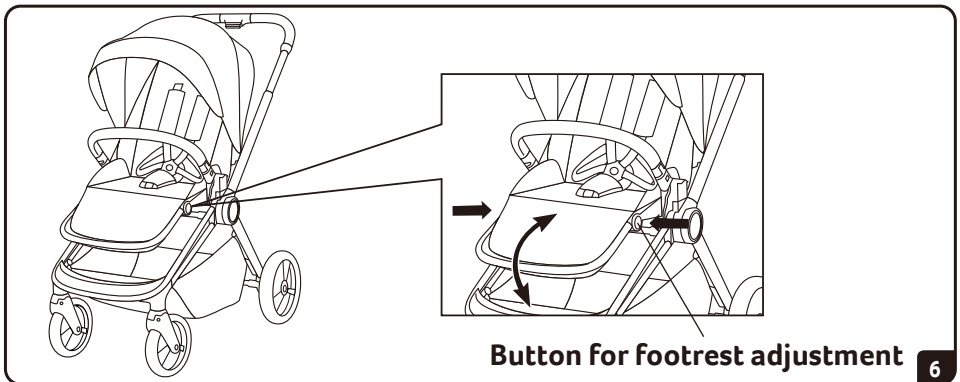

6. To adjust the angle of the footrest, press the button on each side then rotate the footrest to the desired angle.

## Folding instructions

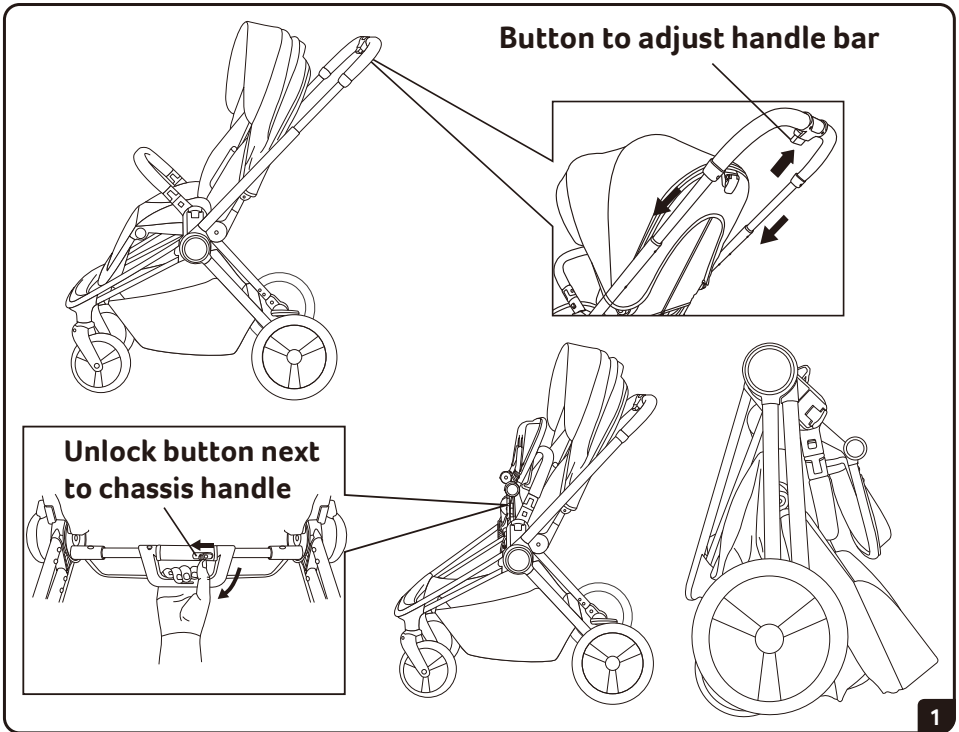

**1. To fold the travel system in forward facing mode, first lower the handle bar into the lowest position and push the footrest upwards.**

**While holding the chassis handle, unlock the button with your thumb - as you lift the chassis handle upwards the chassis will fold.**

## Folding instructions

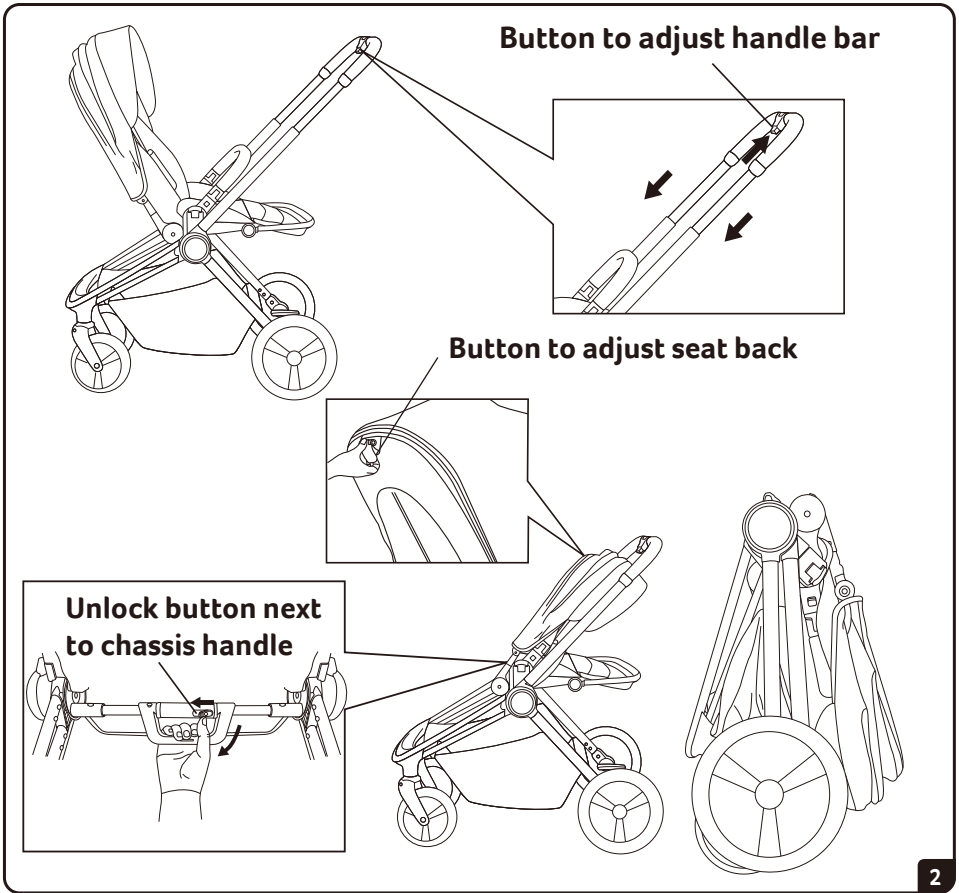

2. To fold the travel system in parent facing mode, first lower the handle bar into the lowest position, adjust the backrest forwards and push the footrest upwards.

While holding the chassis handle, unlock the button with your thumb - as you lift the chassis handle upwards the chassis will fold.

## Maintenance instructions:

- To ensure your baby is protected from accidental injury, please check and maintain the travel system regularly.
- Please use a cloth or brush to clean the seat fabric and use household soap or neutral detergent to clean other parts.
- Please do not store in direct sunlight and rain.
- Regularly check if there are loose screws, damaged parts or broken stitches, if necessary replace the damaged parts.
- Please use the travel system carefully following the instructions to avoid damage or accidental injury.

## Attention:

- Please check all components are installed correctly and fastened in place before each use.
- Do not let the child climb into / out of travel system or stand on the seat or carrycot.
- Do not use the stroller on rough ground, near fire and other dangerous areas.
- Avoid using or storing the travel system in wet, cold or high temperature environments, keeping it away from fire or strong heat.

### Contact Mee-go:

Mee-go Ltd  
Unit 5, Victoria Mills  
Mill Street, Dewsbury  
West Yorkshire  
United Kingdom WF12 9AQ



[www.mee-go.co.uk](http://www.mee-go.co.uk)